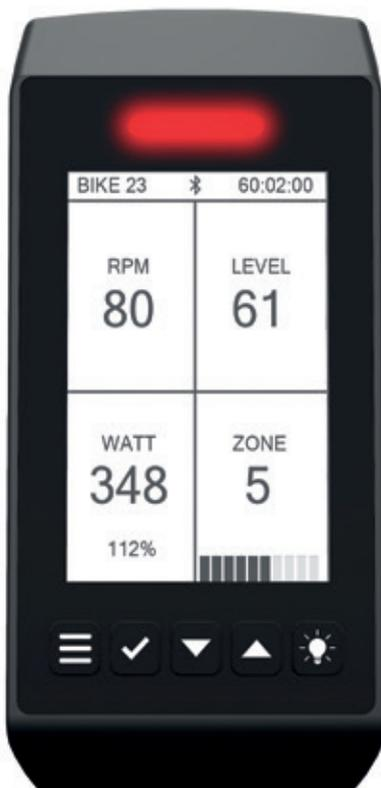

**MANUFACTURED BY:**

Cy-Tech GmbH  
Happurger Str. 86  
90482 NUERNBERG | Germany  
[info@indoorcycling.com](mailto:info@indoorcycling.com)  
[www.indoorcycling.com](http://www.indoorcycling.com)  
Phone: +49(0)911 / 54 44 50

# WATTRATE® LCD COMPUTER

**PART NO:320-00-00019-01****CAUTION!**

READ ALL PRECAUTIONS AND INSTRUCTIONS IN THIS MANUAL BEFORE YOU START USING THIS EQUIPMENT. PLEASE KEEP THIS MANUAL FOR FUTURE REFERENCE. IMPROPER ASSEMBLY, USE OR MAINTENANCE CAN VOID THE WARRANTY TERMS.

ADDITIONAL LANGUAGES AVAILABLE FOR DOWNLOAD AT [WWW.INDOORCYCLING.COM](http://WWW.INDOORCYCLING.COM)

Version 2.0 WattRate LCD Computer | Copyright by Cy-Tech GmbH 2021 | [www.indoorcycling.com](http://www.indoorcycling.com)



# ATTENTION



EN

To download the owners manual in your language, visit the support section at: [www.teamigc.com](http://www.teamigc.com)



DE

Um das Handbuch in Ihrer Sprache herunterzuladen, besuchen Sie bitte den Support Bereich auf unserer Webseite unter [www.teamigc.com](http://www.teamigc.com)



FR

Pour télécharger le manuel d'utilisation dans votre langue, consultez la section Assistance sur: [www.teamigc.com](http://www.teamigc.com)



IT

Per scaricare il manuale nella vostra lingua, visitate la sezione del supporto per su: [www.teamigc.com](http://www.teamigc.com)



NL

Ga om de gebruiksaanwijzing in uw taal te downloaden naar het supportgedeelte onder: [www.teamigc.com](http://www.teamigc.com)



ES

Para descargarse el manual de usuario en su idioma, por favor acceda a la sección de soporte técnico de la bici en: [www.teamigc.com](http://www.teamigc.com)



PT

Para transferir o manual de utilizador no seu idioma, visite a secção „Suporte“ da em: [www.teamigc.com](http://www.teamigc.com)



DK

Besøg supportafsnittet [www.teamigc.com](http://www.teamigc.com) for at downloade brugermanualen på dit sprog



FI

Lataa omistajan käsikirja omalla kielelläsi-ohjeosiosta sivustolta: [www.teamigc.com](http://www.teamigc.com)



NO

Du kan laste ned bruksanvisningen på ditt eget språk ved å gå til støttesiden på: [www.teamigc.com](http://www.teamigc.com)



SE

Du kan hämta bruksanvisningen på ditt språk under-support på [www.teamigc.com](http://www.teamigc.com)



PL

Aby pobrać podręcznik użytkownika w swoim języku, należy wejść na zakładkę support na stronie: [www.teamigc.com](http://www.teamigc.com)



TR

Kullanıcı kılavuzunu kendi dilinizde indirmek için [www.teamigc.com](http://www.teamigc.com) sayfasının deste bölümünü ziyaret edebilirsiniz



CN

在的客户服务网站，您可以下载各种语言的用戶手册 [www.teamigc.com](http://www.teamigc.com)



JP

オーナーズマニュアルの各言語版は、以下サイトの サポートページからダウンロードいただけます。 [www.teamigc.com](http://www.teamigc.com)



KR

지원 센터([www.teamigc.com](http://www.teamigc.com))에서 해당 언어 버전의 사용설명서를 다운로드할 수 있습니다..

# CONTENTS

<b>IMPORTANT PRECAUTIONS</b>	<b>P.4</b>
<b>ASSEMBLY</b>	<b>P.5</b>
<b>BASICS</b>	<b>P.6</b>
<b>DEFINITION TERMS &amp; ABBREVIATIONS</b>	<b>P.8</b>
<b>COACH BY COLOR® TRAINING ZONES</b>	<b>P.9</b>
<b>MEDICAL DISCLAIMER</b>	<b>P.10</b>
<b>SETUP GENERAL SETTINGS</b>	<b>P.11</b>
<b>CONNECTIVITY</b>	<b>P.12</b>
<b>TRAINING MODES/PAUSE MODE</b>	<b>P.13</b>
<b>QUICK-START MODE</b>	<b>P.14</b>
<b>POWER TRAINING</b>	<b>P.15</b>
<b>HEART RATE TRAINING</b>	<b>P.18</b>
<b>FTP RAMP TEST</b>	<b>P.21</b>
<b>FTP 5 MINUTE TEST</b>	<b>P.22</b>
<b>SETTINGS</b>	<b>P.23</b>
<b>SETTINGS GENERAL</b>	<b>P.24</b>
<b>BRAKE CALIBRATION/SETTINGS- OFFSET</b>	<b>P.25</b>
<b>SYSTEM/ANT+ /BLUETOOTH</b>	<b>P.26</b>
<b>TRAINING MODES</b>	<b>P.27</b>
<b>KEY FUNCTIONS</b>	<b>P.28</b>
<b>MAXIMUM DISPLAY RANGES</b>	<b>P.29</b>
<b>EU DECLARATION OF CONFORMITY</b>	<b>P.30</b>
<b>FCC CONFORMITY</b>	<b>P.31</b>
<b>DISPOSAL ELECTRIC WASTE</b>	<b>P.33</b>
<b>INSTALLATION AND DISPOSING OF BATTERIES</b>	<b>P.34</b>

# IMPORTANT PRECAUTIONS

## WARNING!

To reduce the risk of serious injury due to improper use, carefully read and adhere to the safety precautions and information before using the device. Please also take note of the precautions in the Indoor Cycle Manual, with which this computer is to be used.

1. It is the responsibility of the owner to ensure that all users are informed of all warnings and precautions for proper use, and are only authorized to use the bike independently after being successfully briefed by a qualified trainer or instructor.
2. Keep the indoor cycle indoors, away from moisture and dust. Do not place the indoor cycle outdoors in a garage or covered patio or near water or pools. Operating temperature of the indoor cycle has to be between 15°C ~ 40°C Celsius (59°F~104°F) at a maximum humidity of 65%.
3. Children under the age of 14 shall only be allowed to use the indoor cycle with parental approval and supervision of a qualified Trainer or Instructor. Use of the bike by persons over the age of 14 only to be allowed after a qualified Trainer or Instructor briefs them. Unsupervised children should be kept away from the training device at all times.
4. All data shown on the display, especially the Watt values generated by the integrated power sensor, serve merely as information and to help guide training. Only exercise within your physical limitations.
5. If you feel pain or dizziness while exercising, stop immediately. It is recommended that you consult a doctor if the pain does not subside for an extended period of time.
6. Heart rate monitoring systems may be inaccurate. Over exercising may result in serious injury or death. If you feel faint stop exercise immediately !

## CAUTION

If you have pre-existing health problems or a disability, it is recommended that you consult your physician, in order to find the training method which is best suited to you. Incorrect or extensive training can result in serious health injuries. The manufacturer expressly assumes no responsibility for health risks, personal injury, property damage or consequential damages sustained by or through the use of this device, unless it is a case of consequential damage which can be traced back to faulty material and/or manufacturing, and which come under the responsibility of the manufacturer.

# ASSEMBLY

Please first check the contents of the package to make sure nothing is missing.

## Included with delivery

- 1x 320-00-00019-01 • 1x Holder for handlebar clamp
- 1x Allen bolt M4 x 20 • 1x User manual

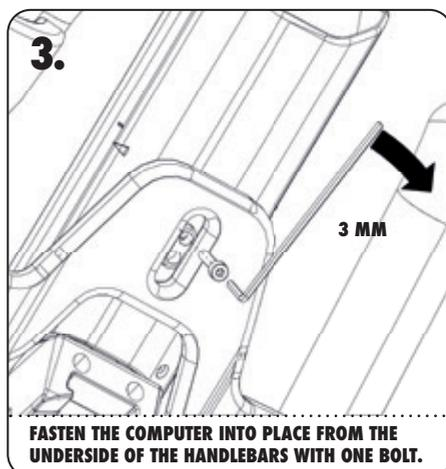
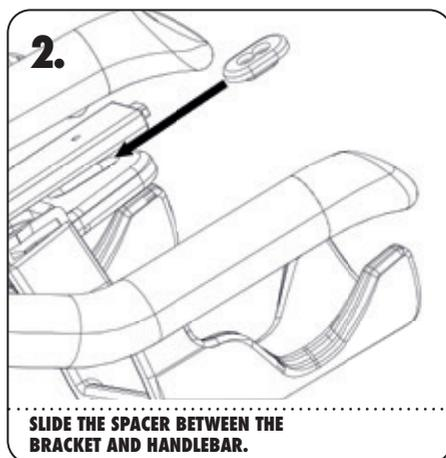
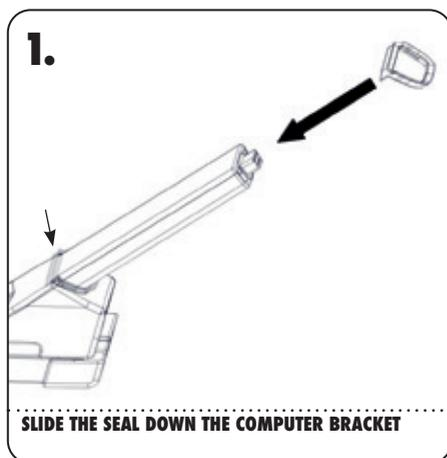

# BASICS

**5 COLOR LED INDICATOR FOR COACH BY COLOR TRAINING**



Use the arrow keys within the menus to navigate up or down as well as the confirm key to enter/confirm your selection.

# BASICS

## SWITCH ON

Until the flywheel is moved, the computer is in deep sleep mode. To switch the computer from standby mode to operational mode, simply perform one full revolution with the pedal. After approx. 5 seconds, the computer is then switched on and the display activated.

## SWITCH OFF

The computer is automatically switched off if the wheel is not moving. The switch off time is extended if the console is operated or if you switch to pause mode.

- The console is automatically switched off after two minutes if it is not operated and the flywheel is not moving.
- The switch off time lasts for 5 minutes if it is in pause mode and the flywheel is not moving.
- Each time a button is pressed, the switch off time is reset to the time interval entered here.

## BATTERY STATUS DISPLAY

If the the battery is almost depleted, a flashing battery symbol is shown on the top of the display.

Please note that as long as the battery status display is active, the console may switched off suddenly and replacement of the batteries is required.

## POWER SUPPLY

The bike computer requires 2 D-cell batteries, which are used in the Ride CX/IC5. Please refer to the Ride CX/IC5 manual for replacing the batteries.

## ACCURACY

The average displayed values on the IC5 are accurate within  $\pm 10\%$  at 50 - 120 RPMs at a power of 50 - 900 watts.

# DEFINITION TERMS & ABBREVIATIONS

**COACH BY COLOR® (CBC)** Power-orientated (WattRate®) or heart rate oriented training guidance based on individual user settings by training zones depicted in color.

**WATT** Unit of power which is calculated based on the time during which the work is done. The calculation is carried out using the formula:  $\text{Watts} = \text{force} \times \text{speed}$ . With respect to cycling this means:

Watts = the pressure applied by the cyclist to the pedal /traction x peddling frequency/cadence.

In Indoor Cycling, the power rendered is regulated using the resistance dial. The speed is regulated by the cadence.

**WATTRATE®** Direct measurement of the power rendered by the cyclist in real time.

**FTP** Functional Threshold Power®, also termed FTP Index. Power delivered in Watts to the functional threshold power (FTP = 100% corresponds to the aerobic/anaerobic power threshold)

**FTP%** Functional Threshold Power® in per cent. Information on the current power with respect to the FTP value in per cent  $\text{FTP}\% = (\text{current power in Watts} / \text{FTP}) \times 100$

**RPM** Revolutions Per Minute, Cadence, pedaling frequency (PFQ), Revolutions Per Minute (R/min)

**HR** Heart Rate

**HR MAX %** Information on the current heart rate with respect to the maximum heart rate in percent  $\text{HR MAX \%} = (\text{current HR} / \text{HR max}) \times 100$

**BPM**

Beats per Minute

In this manual, this relates to the heart rate of the user.

**TSS®** allows an endurance athlete the ability to quantify their workouts based on their relative intensity, duration, and frequency of workouts.

**IF®** is an indication of how hard or difficult a ride was in relation to your overall fitness

**EFFORT POINTS** are calculated for your workout depending on the amount of time you ride in the individual training zones. They are displayed in the upper left hand corner of the LCD display during a power or heart rate training and the accumulated effort points may also be displayed during Connect workouts.

**GIVEN POINTS FOR 1 MINUTE OF RIDING IN EACH ZONE:**

<b>1 EFFORT POINT</b>	0-55% of your FTP / 50 – 59% of your HRM
<b>2 EFFORT POINTS</b>	56-75% of your FTP / 60 - 69% of your HRM
<b>3 EFFORT POINTS</b>	76-90% of your FTP / 70 – 79% of your HRM
<b>4 EFFORT POINTS</b>	91-105% of your FTP / 80 – 89% of your HRM
<b>5 EFFORT POINTS</b>	106-120% of your FTP / 90 - 95% of your HRM
<b>5.5 EFFORT POINTS</b>	121- +150% of your FTP / 96 – 100% of your HRM



# COACH BY COLOR® TRAINING ZONES

## COACH BY COLOR® TRAINING CONCEPT

The 5 color zones used by ICG (white, blue, green, yellow, red) can be used based on the power (watts) of every user of the bike. The training zones are based on the current power in relation to the individual FTP (Functional Threshold Power®) value. The same principle of calculating training zones applies when using the maximum heart rate (HR max) and a compatible chest belt. As soon as the max HR or the individual FTP value are known, the personal training zones can be worked out accordingly and in doing so the intensity can be displayed by the colors during the training session based on the heart rate or watts.

Using the FTP power test (ramp test integrated into the computer), the user has the option to monitor both current performance and progress.

## CAUTION

The power test should only be carried out under the supervision and guidance of a qualified Instructor or Trainer.

In both Power Training and Heart Rate Training the user has the option to turn off the Coach By Color® Training Guidance by selecting Color Mode OFF if he/she wishes.

## COACH BY COLOR® – 5 ZONES

5 Colored Zones	Powered % FTP	Time	% HR <sup>max</sup>	Load
Active Recovery	< 55 %	Infinity	< 60 %	Very Light
Endurance	56 – 75 %	3 – 8 hours	61 – 70 %	Light
 Ignite	67 – 75 %	3 – 8 hours	66 – 70 %	Light/Moderate
Tempo	76 – 90 %	3 – 8 hours	71 – 80 %	Moderate
 Heat	85 – 95 %	10 – 60 min	78 – 85 %	Moderate/Hard
Lactate Threshold	91 – 105 %	10 – 60 min	81 – 90 %	Hard
V02 <sup>max</sup>	> 105 %	1 – 8 min	> 90 %	Hard/Maximal
 On Fire/Anaerobic Capacity	121 – 150 %	1 – 5 min	92 – 94 %	Maximal
 Burn/Neuromuscular Power	> 150 %	5 – 10 sec	95 – 100 %	Maximal

# MEDICAL DISCLAIMER

## CAUTION

The division of the training zones for power or heart rate oriented training is based on an average person's performance. The zones may sometimes vary dramatically depending on the nature of the training, the state of your health (e.g. whether you are taking any medications) and your physical capabilities. It is recommended to always work out sensible training parameters for your own personal training under medical supervision, and to plan your personal training based on this data.

## WARNING

- Do not exercise beyond your ability.
- If you feel physical discomfort or dizziness, stop training and consult a physician.
- Color zones are for guidance only.
- If the user requires medication that has an effect on their performance capabilities and/or cardiovascular system, it is imperative that they consult a doctor in order to adjust the personal entries accordingly.

# SETUP GENERAL SETTINGS

After the computer has been mounted to the bike, it will automatically guide you through the general settings. Select according to your regional or personal preferences.

**LANGUAGE:** Selection menu

**WEIGHT UNITS:** KG/LBS

**DISTANCE UNITS:** KM/MILES

**COLOR MODE:** On/Off

If set to off, the CBC LED indicator will disabled and CBC training will not be possible.

## SHOW QR CODE

If ON, the QR code with ICG App download information will be displayed during cycle start up.

## ICG HEAT TRAINING MODE.

Activates additional color zone animations based on your personal FTP value or your max heartrate.

## BRAKE CALIBRATION

Calibrates the mechanical settings with the displayed information.

## BIKE ID

During installation each bike can be given its own unique bike identification number. The identification number is required for use with ICG Connect and App pairing.

## FINISHING SETUP

Once the selections have been made, you will be referred to the Settings Overview Screen.

Following the instructions on the screen, press the **MENU** button to complete the initial setup.



↑  
**MENU**

# CONNECTIVITY\*

<b>CHEST BELTS</b>		
BLE compatible heart rate sensors	Polar compatible heart rate sensors at 5.5 kHz (coded sensors recommended)	ANT+ compatible heart rate monitors.
<b>ICG APP**</b>		
You can connect the ICG App to the bike console with your mobile device via Bluetooth (Bluetooth must be manually activated in your mobile device). The app can transfer your personal data such as gender, age, weight and FTP value automatically to your bike console before workouts and record your workouts for personal review.		
<b>BROADCAST DATA**</b>		
Hardware or apps that support ANT+ or BLE technology can in principle receive the provided data.		
	<b>ANT+</b>	<b>BLE</b>
<b>HEART RATE</b>	YES	NO
<b>CADENCE</b>	YES	YES
<b>POWER</b>	YES	YES
* Some features may depend on the installed software version of your WattRate® LCD Computer ** Your mobile device and apps must support the features and they must be enabled before use.		

## **PAIRING THE ICG APP TO THE CONSOLE**

Start the console on the bike until you see the training selection screen. Start the app on your mobile device and follow the instructions.

## **IMPORTANT!**

All compatible apps must be paired with the LCD in the home screen or in the activated pause mode.

# TRAINING MODES

## QUICK START

Quick start, without entering any user settings.

## POWER TRAINING

Detailed entry of user settings including index values (for FTP and max HR) as well as optional connection to a compatible chest belt. Training zone guidance is based on watts (power)

## HEART RATE TRAINING

Requires a compatible chest belt, detailed entry of user settings and index values (for FTP and max HR) Training zone guidance is based on heart rate

## POWER TEST

Will allow you to select between 2 power tests. Please refer to our page 21 for further information.

# PAUSE MODE

To pause the time during a workout, press the tick button to enter the pause mode when you are in one of the main training screens



↑  
PAUSE

If no button is pressed in 10 minutes, the computer switches off. The entered or recorded values are lost.

## RESUME

By pressing confirm, the current workout will be resumed.

## SUMMARY

When selected, an overview of the stats from your training session are displayed.

## RESTART WORKOUT

Begins a new workout and keeps the user settings.

## END WORKOUT

Ends workout and records workout data if paired with a mobile device.

# QUICK-START MODE

Select Quick-Start Mode, and begin training.  
Once started, the following Information is displayed on the screen.

<b>RPM</b> Current Cadence	<b>LEVEL</b> Resistance (0-100)
<b>WATT</b> Current Power Output	<b>KCAL</b> Kilocalories burned
<b>DISTANCE</b> Distance covered	<b>SPEED</b> KMH - MPH

# POWER TRAINING

The Power Training mode enables you to enter additional user settings and to connect the computer to a compatible chest harness. In this mode, the individual threshold (FTP and max HR) can be precisely entered, or if not known, calculated based off the biometric data entered into the console. It is also possible to carry out the Coach By Color® training guidance based on power.

## **WARNING!**

- Systems for monitoring heart rate may not be completely accurate.
- Excessive exercise can cause severe damage to health and can even result in death.
- If you feel dizzy or weak, stop exercising immediately.
- This device is not intended to be used by persons (including children) with restricted physical sensory or mental capabilities or with a lack of experience and/or knowledge, unless they are supervised by someone responsible for their safety or have received instructions from this person on how to use the device (e.g. from a doctor, trainer, etc.).
- Children must be supervised at all times to ensure that they do not play with the equipment.
- An additional consent is provided by the user when the Medical Disclaimer is acknowledged by pressing the button at the beginning of the training session in Power Training or Heart Rate Training Mode.

## **CAUTION:**

The calculated FTP values are intended as a guide. but in order to receive precise values, we advise carrying out the FTP Power Test.

# POWER TRAINING

**FOLLOW THE STEP BY STEP DIRECTIONS CAREFULLY AS PROMPTED ON THE DISPLAY TO START A TRAINING SESSION.**

The power training mode has 4 screens that display different information during training. Toggle between the screens by pressing the arrow buttons.

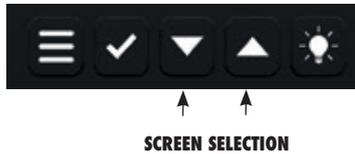

SCREEN 1

<b>RPM</b> Current Cadence	<b>LEVEL</b> Resistance (0-100)
<b>WATT</b> Current Power Output <b>% OF FTPV</b>	<b>ZONE</b> Current Training Zone Indication until next zone 

SCREEN 2

 % % of max Heart rate	<b>KCAL</b> Calories burned
<b>MI/KM</b> Distance	<b>MPH/KMH</b> Speed
<b>WATT/KG</b> The Wattage per kg of body weight	<b>WATT/HR</b> The average Wattage with respect to average HR



# POWER TRAINING

SCREEN 3

<b>WATT MAX</b> Maximum power reached in WATTS	<b>WATT AVG</b> Average output power in WATTS
<b>♥ MAX</b> Max Heart Rate	<b>♥ AVG</b> Average Heart Rate
<b>RPM MAX</b> Maximum cadence reached	<b>RPM AVG</b> Average cadence achieved
<b>MPH/KMH MAX</b> Maximum Speed Reached	<b>MPH/KMH AVG</b> Average Speed Achieved

SCREEN 4

<b>FTP IN %</b>	<b>RED / ZONE 5</b>
<b>TIME IN ZONE</b>	<b>% OF TIME IN ZONE 5</b>
<b>FTP IN %</b>	<b>YELLOW / ZONE 4</b>
<b>TIME IN ZONE</b>	<b>% OF TIME IN ZONE 4</b>
<b>FTP IN %</b>	<b>GREEN / ZONE 3</b>
<b>TIME IN ZONE</b>	<b>% OF TIME IN ZONE 3</b>
<b>FTP IN %</b>	<b>BLUE / ZONE 2</b>
<b>TIME IN ZONE</b>	<b>% OF TIME IN ZONE 2</b>
<b>FTP IN %</b>	<b>WHITE ZONE 1</b>
<b>TIME IN ZONE</b>	<b>% OF TIME IN ZONE 1</b>

Dynamic overview of training zones and time.

The absolute time spent and percentage of the time in which you were training in each zone is displayed.

# HEART RATE TRAINING

The Heart Rate Training mode enables you to enter additional user settings and to connect the computer to a compatible chest harness. In this mode, the individual threshold (FTP and max HR) can be precisely entered, or if not know calculated based off the biometric data entered into the console. It is also possible to carry out the Coach By Color® training guidance based on heart rate.

## **WARNING!**

- Systems for monitoring heart rate may not be completely accurate.
- Excessive exercise can cause severe damage to health and can even result in death.
- If you feel dizzy or weak, stop exercising immediately.
- This device is not intended to be used by persons (including children) with restricted physical sensory or mental capabilities or with a lack of experience and/or knowledge, unless they are supervised by someone responsible for their safety or have received instructions from this person on how to use the device (e.g. from a doctor, trainer, etc.).
- Children must be supervised at all times to ensure that they do not play with the equipment.
- An additional consent is provided by the user when the Medical Disclaimer is acknowledged by pressing the button at the beginning of the training session in Power Training or Heart Rate Training Mode.

## **CAUTION:**

The calculated FTP values are intended as a guide. but in order to receive precise values, we advise carrying out the FTP Power Test.

# HEART RATE TRAINING

**FOLLOW THE STEP BY STEP DIRECTIONS CAREFULLY AS PROMPTED ON THE DISPLAY TO START A TRAINING SESSION.**

The heart rate training mode has 4 screens that display different information during training. Toggle between the screens by pressing the arrow buttons.



**SCREEN SELECTION**

**SCREEN 1**

<p><b>RPM</b> Current Cadence</p>	<p><b>LEVEL</b> Resistance (0-100)</p>
<p><b>BPM</b> Heart Rate</p>	<p><b>ZONE</b> Current Training Zone</p> <p>Indication until next zone</p>

**SCREEN 2**

<p><b>WATT %</b> Watt as percentage based on FTP value.</p> <p><b>WATTS</b> Current output power in Watts</p>	<p><b>KCAL</b> KCalories burned</p>
<p><b>MILES/KM</b> Distance</p>	<p><b>MPH/KMH</b> Speed</p>
<p><b>WATT/KG</b> The Wattage per kg of body weight</p>	<p><b>WATT/HR</b> The average Wattage with respect to average HR</p>

# HEART RATE TRAINING

SCREEN 3

<b>WATT MAX</b> Maximum power reached in WATTS	<b>WATT AVG</b> Average output power in WATTS
<b>♥ MAX</b> Max Heart Rate	<b>♥ AVG</b> Average Heart Rate
<b>RPM MAX</b> Maximum cadence reached	<b>RPM AVG</b> Average cadence achieved
<b>MPH/KMH MAX</b> Maximum Speed Reached	<b>MPH/KMH AVG</b> Average Speed Achieved

SCREEN 4

♥ MAX IN %	ZONE 5
TIME IN ZONE	% OF TIME IN ZONE 5
♥ MAX IN %	ZONE 4
TIME IN ZONE	% OF TIME IN ZONE 4
♥ MAX IN %	ZONE 3
TIME IN ZONE	% OF TIME IN ZONE 3
♥ MAX IN %	ZONE 2
TIME IN ZONE	% OF TIME IN ZONE 2
♥ MAX IN %	ZONE 1
TIME IN ZONE	% OF TIME IN ZONE 1

During the work out, one of the 5 training zones is highlighted depending on the training zone you are currently in.

# FTP RAMP TEST

The FTP (power) test makes it possible to determine a user's individual FTP value in an evaluation test, or to monitor the workout progress.

The test is designed as a so-called "ramp test". As soon as the test is started, a target value of 75 watts (+/- 15W) is specified. The user taking the test is now requested to maintain a constant and comfortable cadence of between 70 and 90 RPM throughout the entire test and to turn the resistance dial to set the resistance so that the target value is achieved.

The target value must be reached within a window of max +/- 15 W deviation, otherwise the CBC LED changes to red. If the target value is met, the CBC LED changes to green. The target value increases every 4 minutes by 25 watts and the test can be ended at any time. After the first target value is reached after 4 minutes (75 watts for 4 minutes), the result is shown after ending the test. If it is interrupted beforehand, the test fails.

If you are notified that you have been outside the target range for longer than 24 seconds within a 4 minute ramp then a FTP value will be calculated but we would suggest you repeat the test for a more accurate result.

Please note that only fully completed ramps (4 minutes) are taken into consideration for the test results.

## CAUTION

- The integrated FTP (power) test in the form of a 4 minute "ramp test" represents a subjective test, which the user can end at any point.
- The FTP (power) test should only be carried out under the supervision of a qualified and experienced trainer or instructor.
- It is recommended to constantly monitor the heart rate during the test, in order to control the physical exertion caused by the output power. Over-exertion must under no circumstances take place.
- Please also take note of the Medical Disclaimer.

Your current cadence. <b>RPM</b>	Your current resistance <b>LEVEL</b>
Your current power output <b>WATT</b>	Target Power Output <b>TARGET</b>
Time until next ramp is reached <b>RAMP TIME</b>	Current Ramp Number <b>RAMP</b>

# FTP 5 MINUTE TEST

The 5 minute Functional Threshold Power test determines your FTP value and gives a personal value for setting intensity making your workouts more effective and allowing you to monitor your fitness progress.

The test is carried out by riding at a maximum sustainable effort of resistance for the full 5 minutes and by staying within the target cadence range of 80 - 100 RPM. The CBC LED will light Green if you are pedaling within the cadence range and Red if you are pedaling too slow or too fast. If necessary during the test you may adjust the resistance during the test to achieve your maximum power output within the cadence range of 80 - 100 RPMs. Staying within the cadence range as much as possible will provide a more accurate test result.

Before you start the test, be sure you have completed a full warm up.

A 60 second countdown will commence the start of the test.

Begin pedaling and adjust the resistance and maintain the correct cadence.

Once you have finished the test, perform a proper COOL DOWN.

Note your FTP value for future use with Coach By Color Power Training and monitoring your fitness progress.

## CAUTION

- The integrated FTP (power) test in the form of a 5 minute test represents a subjective test, which the user can end at any point.
- The FTP (power) test should only be carried out under the supervision of a qualified and experienced trainer or instructor.
- It is recommended to constantly monitor the heart rate during the test, in order to control the physical exertion caused by the output power. Over-exertion must under no circumstances take place.
- Please also take note of the Medical Disclaimer.

Your current cadence.	Your current resistance
<b>RPM</b>	<b>LEVEL</b>
Your current power output	Avg. Power Output
<b>WATT</b>	<b>WATT AVG</b>

# FTP 20 MINUTE TEST

The 20 minute Functional Threshold Power test determines your FTP value and gives a personal value for setting intensity making your workouts more effective and allowing you to monitor your fitness progress.

The test is carried out by riding at a maximum sustainable effort of resistance for the full 20 minutes and by staying within the target cadence range of 70 - 100 RPM. The computer will light Green if you are pedaling within the cadence range and Red if you are pedaling too slow or too fast. If necessary during the test you may adjust the resistance during the test to achieve your maximum power output within the cadence range of 70 - 100 RPMs. Staying within the cadence range as much as possible will provide a more accurate test result.

Before you start the test, be sure you have completed a full warm up.

A 60 second countdown will commence the start of the test.

Begin pedaling and adjust the resistance and maintain the correct cadence.

Once you have finished the test, perform a proper COOL DOWN.

Note your FTP value for future use with Coach By Color Power Training and monitoring your fitness progress.

## CAUTION

- The integrated FTP (power) test in the form of a 20 minute test represents a subjective test, which the user can end at any point.
- The FTP (power) test should only be carried out under the supervision of a qualified and experienced trainer or instructor.
- It is recommended to constantly monitor the heart rate during the test, in order to control the physical exertion caused by the output power. Over-exertion must under no circumstances take place.
- Please also take note of the Medical Disclaimer.

Your current cadence. <b>RPM</b>	Your current resistance <b>LEVEL</b>
Your current power output <b>WATT</b>	Avg. Power Output <b>WATT AVG</b>

# SETTINGS

To access the computer settings, a special key combination must be confirmed which protects the settings menu from unauthorized access.



## TO OPEN THE SETTINGS MENU:

- 1. BE SURE YOU ARE IN THE MODE SELECTION SCREEN (START UP SCREEN)**
- 2. PRESS THE DOWN KEY AND THE BACKLIGHT BUTTON SIMULTANEOUSLY FOR A MINIMUM OF 3 SECONDS.**

Use the arrow keys within the menu navigation to navigate up or down as well as the confirm key to enter/confirm the relevant selection.



# SETTINGS GENERAL

When selected, you can change the general settings as entered when the bike was used for the first time. Please note: when the GENERAL Settings tab is selected, you will be guided through the settings step by step.

**LANGUAGE:** Selection menu

**WEIGHT UNITS:** KG/LBS

**DISTANCE UNITS:** KM/MILES

**COLOR MODE:** On/Off

If set to off, the CBC LED indicator will be disabled and CBC training will not be possible.

**SHOW QR CODE**

If ON, the QR code with ICG App download information will be displayed during cycle start up.

**ICG HEAT TRAINING**

Activates additional indications in the color zones based on your personal FTP value or your maximum heart rate.

## BIKE ID

During installation each bike can be given its own unique bike identification number. The identification number is required for use with ICG Connect and App pairing.

# BRAKE CALIBRATION

The brake must be calibrated if the displayed level of resistance does not reach 0% or 100% at the end positions or an exclamation mark (!) is shown instead of the level as a % on the display.

**FOLLOW THE STEP BY STEP DIRECTIONS CAREFULLY AS PROMPTED ON THE DISPLAY.**

If the values lie outside a certain range, the calibration may fail and a red screen will appear.

Reattempt the calibration and make sure you follow the instructions carefully.

If the calibration fails again, the resistance system must be adjusted mechanically. Please refer to technical service in this case.

# SETTINGS – OFFSET

An offset measurement was completed in the background.

Follow the step by step directions carefully as prompted on the display.

# SYSTEM

By selecting System, you can access the following:

## **USAGE**

Displays the number of hours in which the indoor cycle has been in use.

## **FIRMWARE**

Displays details of the application, gear module and Ble/Ant+

## **FACTORY SETTINGS**

The bike can be reset to factory settings by confirming within the factory settings menu.

## **SYSTEM CHECK**

The System Check serves as a means of diagnosing errors for the Technical Service Team.

If an error should occur in the electronics, it is recommended to carry out the System Check. If error messages (error codes) are shown on the display, these can be reset by pressing down the confirm button for 2 seconds. After resetting the error message, the system is checked again. If the error messages (error codes) are displayed again, please pass them onto the Technical Service Team.

## **FIRMWARE UPDATE**

If a firmware update is required, you will be notified by ICG. To install an update, select the firmware update and follow the instructions provided with the update.

## **TOUCH SENSITIVITY**

The sensitivity of the computer buttons can be adjusted according to your personal preferences

# ANT+ / BLUETOOTH

See connectivity on page 12

# TRAINING MODES

## AVAILABLE VALUES IN THE VARIOUS TRAINING MODES

In the table below, you can gain an overview of all available values which are displayed in the various training modes.

TRAINING MODE	QUICK-START	POWER TRAINING	HEART RATE TRAINING
RPM	X	X	X
LEVEL%	X	X	X
WATT	X	X	X
FTP %	---	X	X
HR	---	OPTIONAL	X
KCAL	X	X	X
KM/MILES	X	X	X
TIME	X	X	X
SCREEN 1	X	X	X
SCREEN 2	---	X	X
SCREEN 3	---	X	X
SCREEN 4	---	X	X
COACH BY COLOR® (WATTRATE®)	---	X	---
COACH BY COLOR® (HEART RATE)	---	---	X
ADJUSTING THE INDIVIDUAL FTP VALUE	---	X	X
ADJUSTING THE INDIVIDUAL MAXIMUM HEART RATE	---	OPTIONAL	OPTIONAL
PAUSE FUNCTION	X	X	X

# KEY FUNCTIONS

The key functions within the various modes are as follows:

<b>SETTINGS MODE</b>		
Down arrow	Press	Scroll down / reduce value
Down arrow	Press and hold	Reduce the value incrementally
Up arrow	Press	Scroll up / increase value
Up arrow	Press and hold	Increase the value incrementally
Menu	Press	No function / exit menu, back
Confirm	Press	Confirm entry
Menu & Confirm	Press simultaneously for 3 seconds	Open settings menu
<b>USER MODE</b>		
Down arrow	Press	Scroll down / reduce value
Down arrow	Press and hold	Reduce the value incrementally
Up arrow	Press	Scroll up / increase value
Up arrow	Press and hold	Increase the value incrementally
Menu	Press	Exit
Confirm	Press	Confirm entry
Menu & Confirm	Press simultaneously for 3 seconds	Open settings menu
<b>TRAINING MODE</b>		
Down arrow	Press	Switch to previous screen
Down arrow	Press and hold	No function
Up arrow	Press	Switch to next screen
Up arrow	Press and hold	No function
Menu	Press	Open user menu
Confirm	Press	Start pause mode
Menu & Confirm	Press simultaneously for 3 seconds	Open settings menu

# MAXIMUM DISPLAY RANGES

<b>TRAINING VALUES</b>		
<b>DISPLAY VALUE</b>	<b>VALUE RANGE</b>	<b>UNITS</b>
Distance	999.9	km or miles
Speed	99.9	km/h or MPH
Workout duration Duration in workout zones	24:00:00	hh:mm:ss
FTP %	unlimited	%
HR %	unlimited	%
HR BPM	30 – 250	BPM
LEVEL	0 – 100	%
RPM (1)	30 – 230	RPM
WATT (2)	0 – 2500	Watt
Calorie consumption	0 – 9999	kcal (displayed as CAL)
<b>USER SETTINGS</b>		
<b>DISPLAY VALUE</b>	<b>VALUE RANGE</b>	<b>UNITS</b>
Age	14 – 99	Years
Weight	34 – 150 or 75 - 331	kg or lbs (pounds)
Workouts per week	0 – 10	Hours
FTP Index (3)	0 – 2500	Watts
HR max (4)	30 – 250	BPM

# MAXIMUM DISPLAY RANGES

**ABOUT (1):**

From a cadence of 150 RPM, the value begins to flash. This is intended to indicate that you are exceeding the exercise range for which the bike was designed. From a cadence of 230, the RPM display is deactivated.

**PLEASE NOTE:**

If the bike is used at cadences of > 180 RPM for extended periods of time, all warranty claims are void.

**ABOUT (2):**

The power is only displayed from a rotational speed of 50 RPM.

**ABOUT (3):**

Value can only be adjusted in the power and heart rate training modes

**ABOUT (4):**

Value can only be adjusted in the power and heart rate training modes and if "CONNECT HR SENSOR" is selected with "YES" in the menu.

**PLEASE NOTE:**

If the maximum value has been reached, the respective value is reset to "0".

## EU- DECLARATION OF CONFORMITY

The electronic components satisfy the EMV Directive 2014/53/EU, EMV Directive 99/519/EC, and DIN EN 60335-1:2012/A14:2019 for electrical safety.

The Declaration of Conformity can be viewed at [www.indoorcycling.com](http://www.indoorcycling.com)



# FCC COMPLIANCE

This device complies with part 15 of the FCC rules. Operation is subject to the following two conditions: (1) This device may not cause harmful interference, and (2) this device must accept any interference received, including interference that may cause undesired operation. Note: This equipment has been tested and found to comply with the limits for a Class B digital device, pursuant to part 15 of the FCC Rules. These limits are designed to provide reasonable protection against harmful interference in a residential installation. This equipment generates, uses, and can radiate radio frequency energy and, if not installed and used in accordance with the instructions, may cause harmful interference to radio communications. However, there is no guarantee that interference will not occur in a particular installation. If this equipment does cause harmful interference to radio or television reception, which can be determined by turning the equipment off and on, the user is encouraged to try to correct the interference by one or more of the following measures: • Reorient or relocate the receiving antenna. • Increase the separation between the equipment and receiver. • Connect the equipment to an outlet on a circuit different from that to which the receiver is connected. • Consult the dealer or an experienced radio/TV technician for help. Important: Changes or modifications to this product not authorized by Indoor Cycling Group could void the electromagnetic compatibility (EMC) and wireless compliance and negate your authority to operate the product. This product has demonstrated EMC compliance under conditions that included the use of compliant peripheral devices and shielded cables between system components. It is important that you use compliant peripheral devices and shielded cables between system components to reduce the possibility of causing interference to radios, televisions, and other electronic devices.

Canadian regulatory statement This device complies with Industry Canada licence-exempt RSS standard(s). Operation is subject to the following two conditions: (1) this device may not cause interference, and (2) this device must accept any interference, including interference that may cause undesired operation of the device.

Le présent appareil est conforme aux CNR d'Industrie Canada applicables aux appareils radio exempts de licence. L'exploitation est autorisée aux deux conditions suivantes : (1) l'appareil ne doit pas produire de brouillage, et (2) l'utilisateur de l'appareil doit accepter tout brouillage radioélectrique subi, même si le brouillage est susceptible d'en compromettre le fonctionnement



# DISPOSAL ELECTRIC WASTE

## EUROPEAN UNION ONLY

This symbol indicates that the product it is referring to may not be disposed of along with normal household waste. If you wish to dispose of this device, do not throw it away along with normal waste! There is a separate collection system for products of this description.



This symbol is only valid in the European Union.

## OTHER COUNTRIES OUTSIDE OF THE EUROPEAN UNION

If you would like to dispose of this product, please adhere to the relevant state laws and other regulations in your country concerning the treatment of electronic devices.

## BUSINESS CUSTOMERS

If you would like to dispose of this product, please get in touch with our service.

## THE BATTERIES MAY NOT:

- Be exploited to fire
- Get in contact with coins or other metal objects
- Be used in combination with older batteries
- Be used with other makes of different types.

Only use LR6 (Alkaline) batteries. If you don't use the equipment for a longer period of time, please remove the batteries to avoid any damage by leaking or corroding batteries. If batteries have are discharged, insert new batteries into the computer. If the batteries have leaked, remove all residue immediately. Avoid contact with eyes and if you come in contact with residue, wash thoroughly. Before scrapping, please take the batteries out of the computer.

## SOFTWARE LICENCE NOTICE

Certain ICG products (including but not limited to MyRide V3, MyRidePlus, MyRide VX, ICG Connect, Wattrate LCD Computer etc.) contain open source software. For further details, please visit <https://support.teamicg.com> or contact [support@indoorcycling.com](mailto:support@indoorcycling.com)

# INSTALLATION AND DISPOSING OF BATTERIES

**YOUR ICG® RIDE CX/IC5 REQUIRES TWO D-CELL BATTERIES (INCLUDED)**

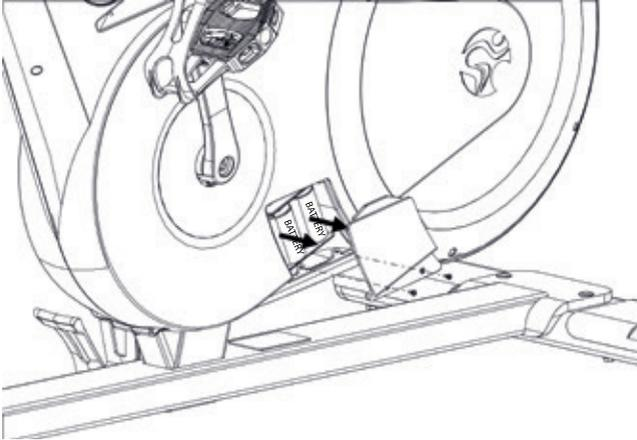

## **BATTERIES MAY NOT:**

- Come into contact with fire
- Come into contact with coins or other metallic objects

Insert the batteries making sure that the positive and negative ends are positioned according to the indication inside the battery compartment. Use D Cell batteries (1.5 V). Never mix used with new batteries.

Products or batteries labelled with this symbol may not be disposed of along with normal household refuse. For proper disposal, please find out about the applicable laws or guidelines on disposing of electrical devices and batteries in your local area and adhere to them.

Signed products or batteries with this symbol may not be disposed of in normal domestic refuse. Please familiarize yourself with relevant local laws or guidelines for disposal of electrical devices and batteries and act accordingly.





## **CAUTION.**

READ ALL PRECAUTIONS AND INSTRUCTIONS IN THIS MANUAL BEFORE YOU BEGIN USING THIS EQUIPMENT. PLEASE KEEP THIS MANUAL FOR FUTURE REFERENCE. IMPROPER ASSEMBLY, SET UP, USE OR MAINTENANCE MAY VOID THE WARRANTY.



**EMAIL:** [INFO@INDOORCYCLING.COM](mailto:INFO@INDOORCYCLING.COM)  
**WEBSITE:** [WWW.INDOORCYCLING.COM](http://WWW.INDOORCYCLING.COM)

© 2021 Cy-Tech GmbH

Manufactured by: Cy-Tech GmbH  
Happurger Str. 86 90482 Nuremberg Germany